

Control Applications of CMOS DACs

National Semiconductor
Application Note 293
March 1986



Control Applications of CMOS DACs

The CMOS multiplying digital-to-analog converter can be widely applied in processor-driven control applications. Because these devices can have a bipolar reference voltage their versatility is increased. In some control applications the

DAC's output capabilities must be substantially increased to meet a requirement while others require substantial additional circuitry to drive a transducer or actuator. A good example of the latter is furnished by *Figure 1*.

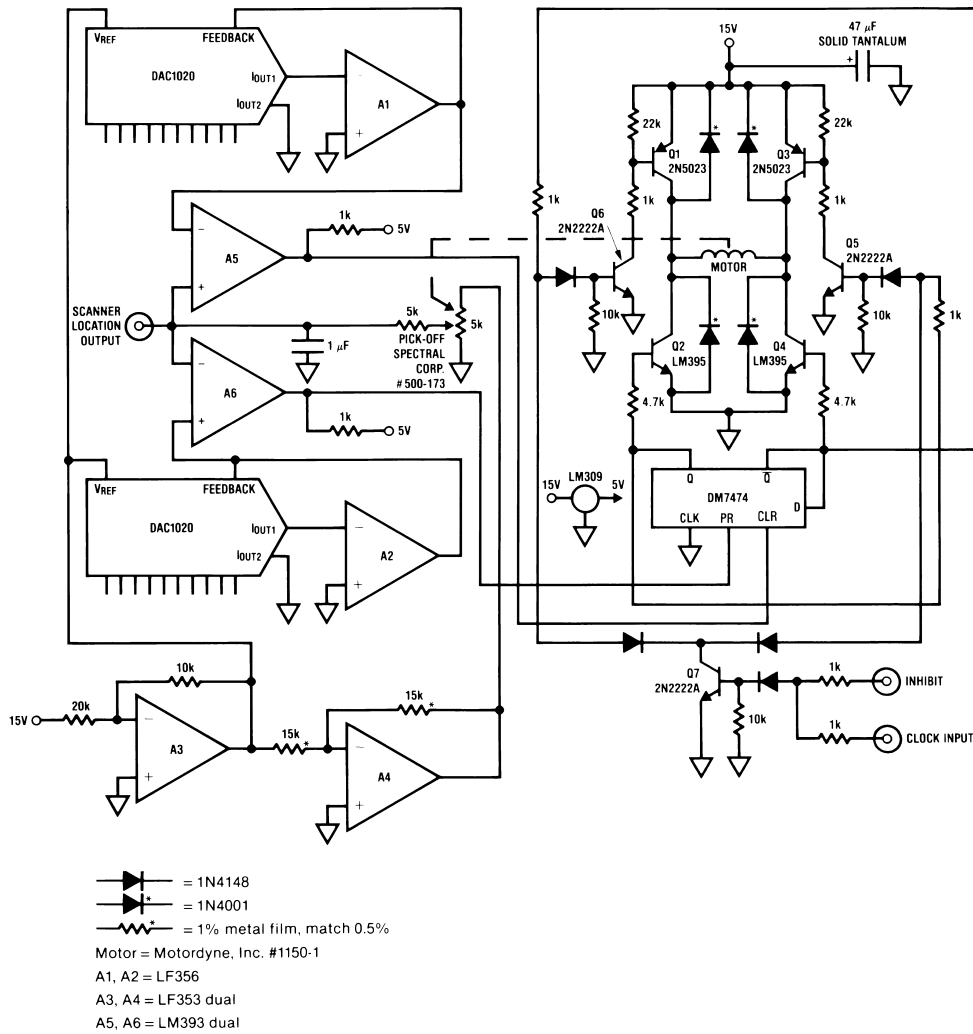

FIGURE 1.

AN005636-1



AN-293

SCANNER CONTROL

Biochemists use a procedure called "scanning electrophoresis" to separate cells from each other. In one form of this process the sample is contained within a vertical glass or quartz tube approximately 1 foot in length. When a high voltage potential is applied across the length of the tube the cells separate along the charge density gradient which runs along the tube's length. This results in a series of stripes or bands within the tube as the individual cells, under the influence of the charge gradient, collect together. When separation is complete, the tube is mechanically scanned along its length by a photometer for optical density characteristics of each band. This information yields useful biochemical information to the experimenter. The scanner must be fully programmable so that it can be run between any two limits at a variety of speeds. In *Figure 1* the two DAC1020 D/A converters establish the limits of the scan. The 5k pick-off potentiometer furnishes scanner location information and the motor drives the scanner (via a gear-train). A5 and A6 are comparators, one of whose outputs goes low when either the high limit (A6 and its associated DAC) or low limit (A5 and its associated DAC) is exceeded. A1 and A2 furnish voltage outputs from the current output of the DACs. A3 and A4 are used to provide suitable reference voltages for the 5k pick-off potentiometer and the DAC reference inputs.

The DM7474 flip-flop is configured in a set-reset arrangement which changes output state each time either A5 or A6 goes low. When the lower limit of the scan is reached, A5 goes low, setting the DM7474's Q output too high. This turns on Q2, Q5 and Q3 resulting in current flow through the motor from Q3 to Q2. This forces the scanner to run towards its high limit. When this limit is reached, A6 goes low and the flip-flop changes state. This turns off the Q2, Q5, Q3 combination and the Q4, Q6, Q1 trio come on, forcing current through the motor in the opposite direction via the Q1-Q4

path. This causes the motor to reverse and proceed toward the lower limit. Q7 is driven by a width-modulated pulse train from the processor which is used to control the scanner's speed via Q5 and Q6. The diodes across Q1, Q2, Q3 and Q4 provide motor spike suppression and the internal current limiting in the LM395s (Q2-Q4) assures short circuit protection.

HIGH VOLTAGE OUTPUT FOR ATE

Testing high voltage components with automatic test equipment (ATE) is often inconvenient because a source of stable, controllable high voltage is required. Adding this capability to a piece of equipment can be expensive and time consuming if standard techniques are used. In *Figure 2* a circuit is shown which has been employed in the testing of high voltage transistors and zeners as well as fuse link blowing in PROMs. In this circuit, a high voltage output is developed by using a Toroidal DC-DC converter within a DAC-controlled pulse-width modulated feedback loop to obtain high voltage. The DAC1020 in conjunction with A1 supplies a setpoint to the LM3524 regulating pulse-width modulator. This set point needs to be within the LM3524's common mode input voltage range of 1.8V to 3.5V. The LM3524's outputs are used to drive the TY-90 toroid via Q1 and Q2. The high voltage square-wave transformer output is rectified and filtered and divided down by the 100k-2.7k string. This potential is fed back to the LM3524, completing a loop. Loop gain and frequency compensation are set by the 1000 pF-100k parallel combination, and the 1Ω resistor at pin 6 of the transformer is used to sense current for short circuit protection. Although the update rate into the DAC can be very fast, the 20 kHz switching of the transformer and the loop time constants determine the available bandwidth at the circuit's output. In practice, a full output sine wave swing of 100V into 1000Ω is available at 250 Hz.

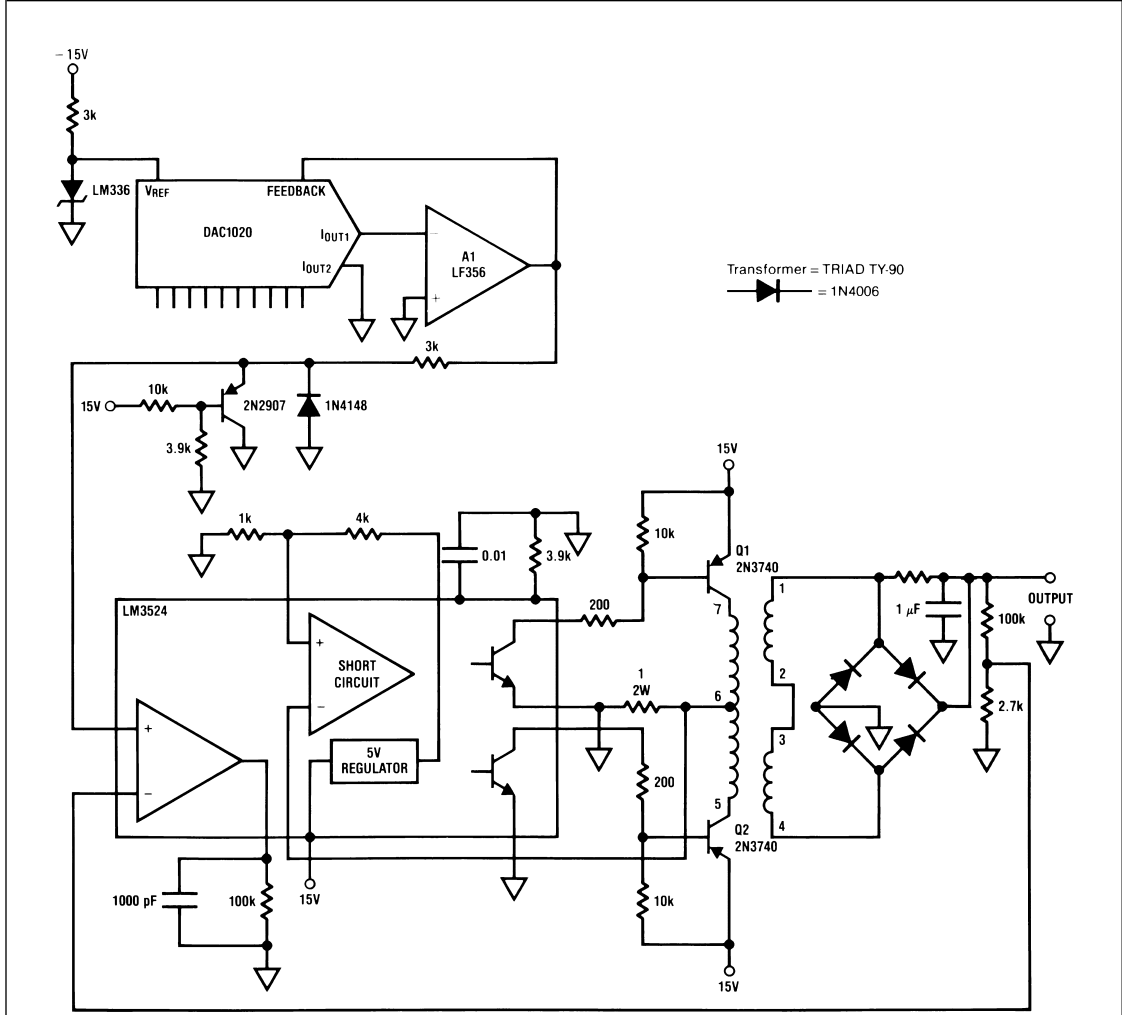

FIGURE 2.

PLATE-DRIVING DEFLECTION AMPLIFIER

Another common high voltage requirement involves deflection plate modulation in CRT and electron-optics applications. Figure 4 shows a pair of DAC1218s used to control both the static (DC) and dynamic (AC) drive to deflection plates in a piece of electron-optic equipment. In contrast to the previous high voltage circuit, this one has very little output current capability but greater bandwidth. The deflection plate load can be modeled as a 50 pF capacitor. In this application, the output of both DAC-amplifier pairs is summed at A3. In practice, one DAC will supply a DC level to the plate (bias) while the other one provides the plate's AC signal, typically a ramp. The high voltage plate drive is furnished by the Q1, Q2, Q3, Q4 configuration which is a complementary

common-base-driven common-emitter output stage. Because the output current requirements are low, the usual crossover distortion problems may be avoided by returning the circuit's output to negative supply via the 120 kΩ resistor. This eliminates notch compensation circuitry and results in a simplified design. Because the high voltage stage inverts, overall negative feedback is achieved by returning the 1 MΩ feedback resistor to A3's positive input. The point now becomes the summing junction for both DAC-driven inputs and the feedback signal. The output of this circuit is clean and quick, as shown in Figure 3. In this figure, 2 complete DAC-driven amplifiers were used to produce the traces. Trace A is the output of A1, while the complementary high voltage outputs are shown in B and C.

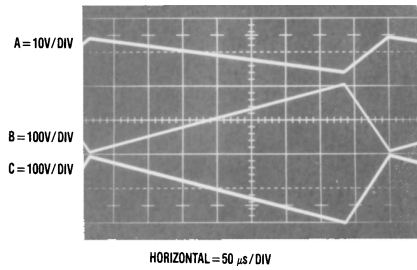

FIGURE 3.

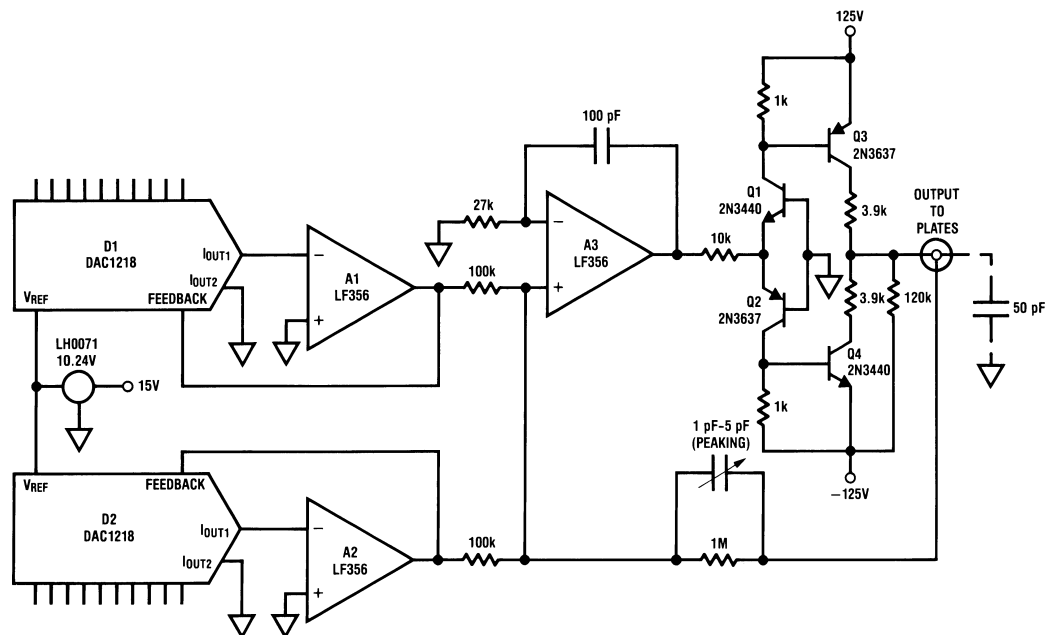

FIGURE 4.

TEMPERATURE LIMIT CONTROLLER

Certain biochemical reactions occur only within very specific temperature limits. The behavior of these reactions within and at the edges of these limits is of interest to biochemists. In order to study these reactions, a special temperature control scheme is required. To meet this requirement, the circuit of *Figure 5* has been employed. In this circuit A1, A3, A4 and A5 comprise a simple pulse-width modulating temperature controller. A4 is an integrator that generates a ramp which is periodically reset to zero by the 10 kHz clock pulse. This ramp is compared to A3 output by A5, which biased the LM395 switch to control the heater. A3's output will be determined by the difference between the temperature setpoint current through the 22.6 kΩ resistor and the current driven

by the LM135 temperature sensor through the 10 kΩ resistor. Thermal feedback from the heater to the LM135 completes the loop. The 10M-1 μF values at A3 set loop response at 0.1 Hz.

Up to this point, the circuit functions as a fixed point temperature controller to provide a stable thermal baseline. To meet the application's requirement, however, the DAC1218 is driven by a slow digitally-coded triangle waveform. The DAC's output is fed to A2, whose output drives the 2 MΩ summing resistor. This causes the controller setpoint to vary slowly and predictably through the desired temperature excursion. This characteristic is observable on a strip-chart recording of the oven's temperature (*Figure 6*) over many hours.

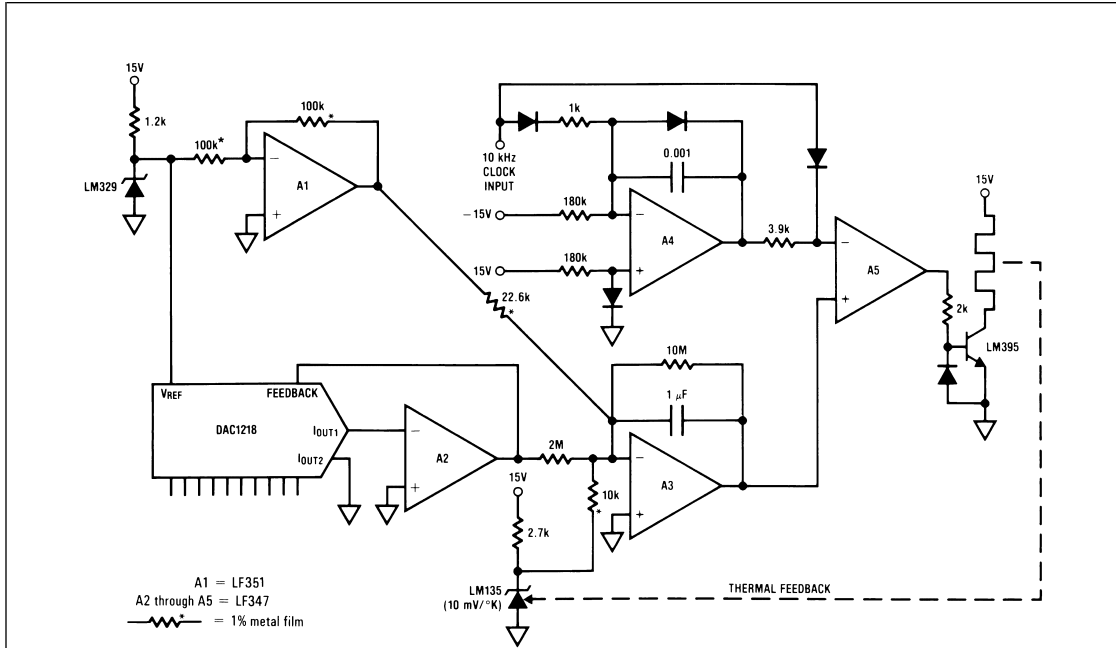

FIGURE 5.

AN005636-8

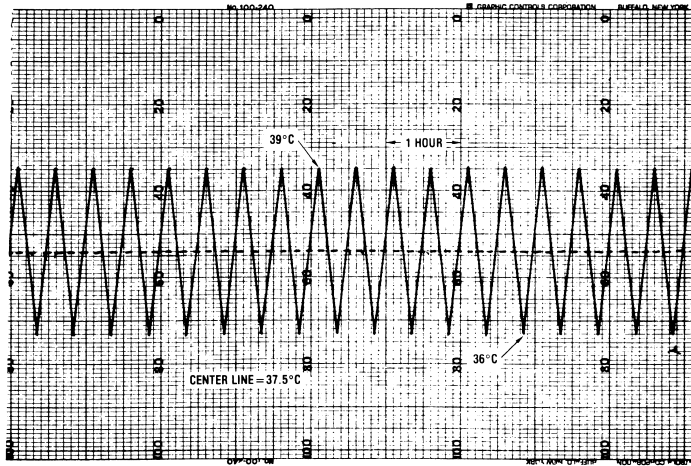

FIGURE 6.

AN005636-9

PROCESSOR CONTROLLED SHAKER-TABLE DRIVE

Shaker-tables are frequently employed to test finished assemblies for vibration induced failures under various conditions of frequency and amplitude. It is often desired to simulate vibration patterns which can greatly vary with duration, frequency and amplitude. In addition, it is useful to be able to vary both amplitude and frequency with precise control over wide dynamic ranges so that narrow resonances in the assembly under test may be observed. The circuit of Figure 7

provides these capabilities. The DAC1218 is used to drive the LF351 integrator. The LF351's output ramps until the current through the 10k resistor just balances the current through the 20k resistor at pin 3 of the LM319 comparator. At this point the comparator changes state, forcing the zener diode bridge and associated series diode to put an equal but opposite polarity reference voltage. This potential is used as the DAC's reference input as well as the feedback signal to

the LM319 "+" input. In this fashion, the integrator output forms a triangle waveform whose output is centered around ground. The DAC input coding controls the frequency, which may vary from 1 Hz to 30 kHz. Calibration is accomplished with the "frequency trim" potentiometer. The triangle waveform is shaped by the 2N3810-LM394 configuration which relies on the logarithmic relationship between V_{BE} and collector current in the LM394 to smooth the triangle into a sine wave. The two potentiometers associated with the shaper are adjusted for minimum indicated distortion on a distortion analyzer. The DAC1020 and the LF356 are arranged in a DAC-controlled gain configuration which allows the ampli-

tude of the sine wave to be varied over a range from millivolts to volts at the LF356 output. The low input impedance and high inductance of a typical shaker-table presents a difficult load for a solid state amplifier to drive, and vacuum tube amplifiers are frequently employed to avoid output stage failures. In this example, the amplifier specified is a well-known favorite for the job because its transformer-isolated input is immune to the inductive flyback spikes a shaker-table can generate. *Figure 8* shows the output waveform when both DACs are simultaneously updated. The output waveform changes in frequency and amplitude with essentially instantaneous response.

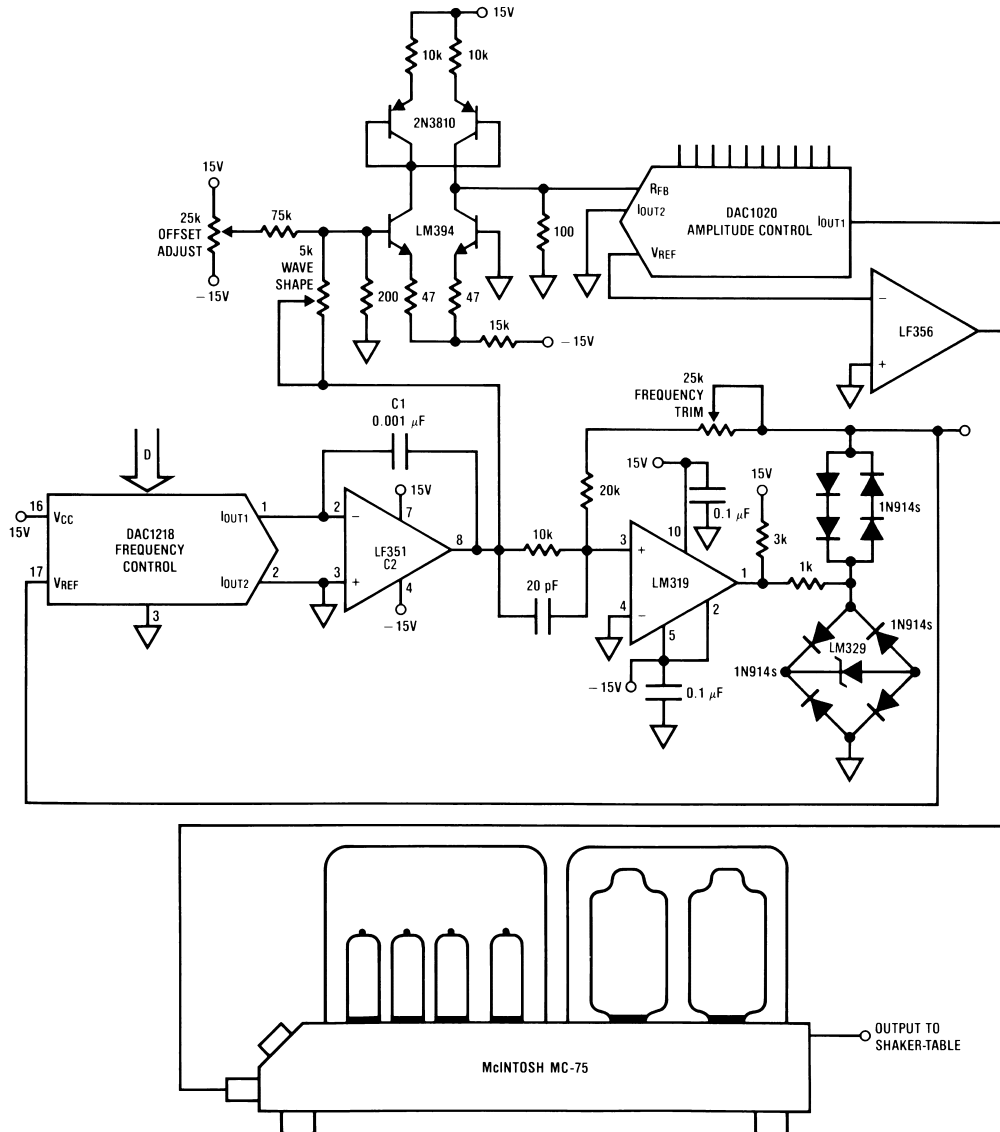
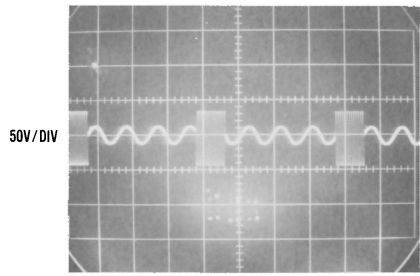

FIGURE 7.

AN005636-6



HORIZONTAL = 2 ms/DIV

AN005636-7

FIGURE 8.

Book
Extract
End

LIFE SUPPORT POLICY

NATIONAL'S PRODUCTS ARE NOT AUTHORIZED FOR USE AS CRITICAL COMPONENTS IN LIFE SUPPORT DEVICES OR SYSTEMS WITHOUT THE EXPRESS WRITTEN APPROVAL OF THE PRESIDENT OF NATIONAL SEMICONDUCTOR CORPORATION. As used herein:

1. Life support devices or systems are devices or systems which, (a) are intended for surgical implant into the body, or (b) support or sustain life, and whose failure to perform when properly used in accordance with instructions for use provided in the labeling, can be reasonably expected to result in a significant injury to the user.
2. A critical component in any component of a life support device or system whose failure to perform can be reasonably expected to cause the failure of the life support device or system, or to affect its safety or effectiveness.

 **National Semiconductor Corporation**
Americas
Tel: 1-800-272-9959
Fax: 1-800-737-7018
Email: support@nsc.com

National Semiconductor Europe
Fax: +49 (0) 1 80-530 85 86
Email: europe.support@nsc.com
Deutsch Tel: +49 (0) 1 80-530 85 85
English Tel: +49 (0) 1 80-532 78 32
Français Tel: +49 (0) 1 80-532 93 58
Italiano Tel: +49 (0) 1 80-534 16 80

National Semiconductor Asia Pacific Customer Response Group
Tel: 65-2544466
Fax: 65-2504466
Email: sea.support@nsc.com

National Semiconductor Japan Ltd.
Tel: 81-3-5620-6175
Fax: 81-3-5620-6179

www.national.com

National does not assume any responsibility for use of any circuitry described, no circuit patent licenses are implied and National reserves the right at any time without notice to change said circuitry and specifications.